

Human-Computer Interaction in a Smart Home Environment

Klaus Fellbaum

Maik Hampicke

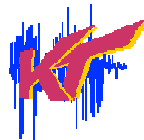

Communication Engineering

Brandenburg University of Technology, Cottbus

- Smart Home
- Learning Home
- User Interfaces for Smart Homes
- Speech and Speaker Recognition
- Investigations and Results
- Summary and Conclusions

Smart Home

Smart Home and Smart Home Environment

- Home (including the narrow environment) with smart technology and services.

Aim...

Integrating, automating and improving

- safety & security,
- communication,
- comfort and,
- energy saving.

Prerequisites:

- Networking,
- adaptation to the user's needs

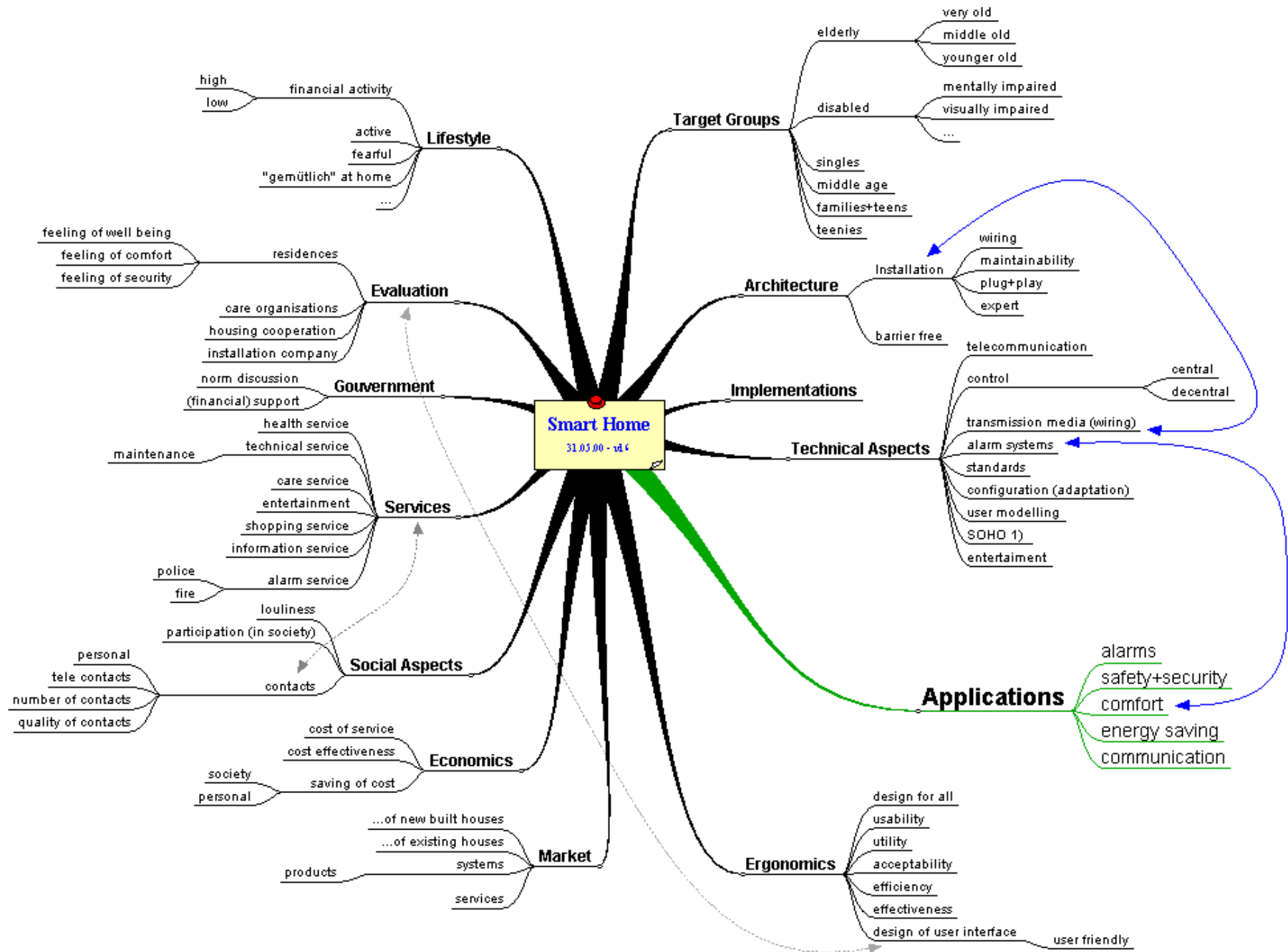

Smart Home Example

External Network

Home Network

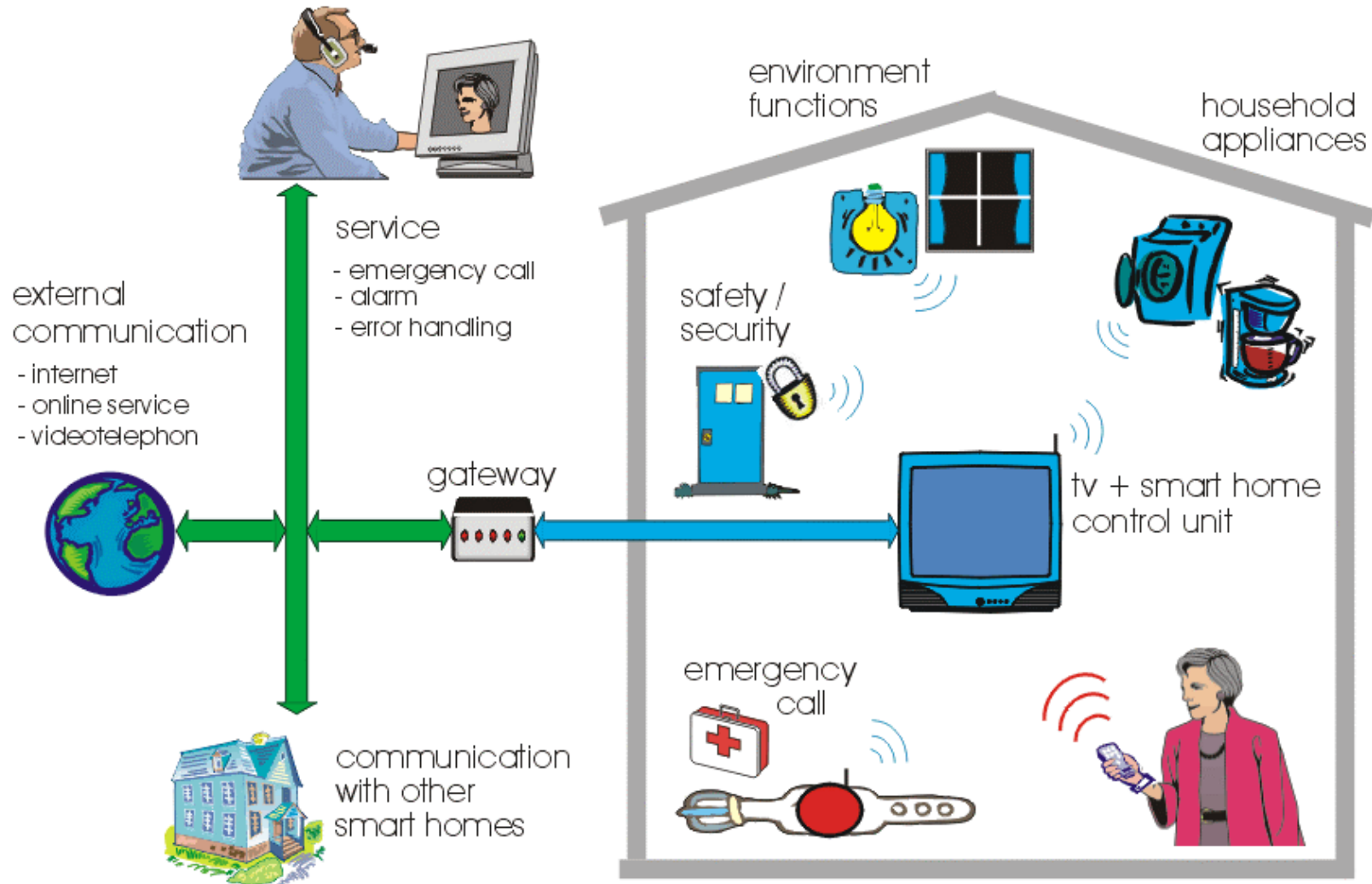

Learning Home: Simulation environment for the Sentha project

Aim

- Realisation,
- demonstration,
- test and evaluation of smart home functions,
- test bed for elderly persons.

Components

- Network,
- control tools, sensors and actuators
- user interfaces,
- speech processing tools
(speech and speaker recognition).



Sentha's Learning Home II

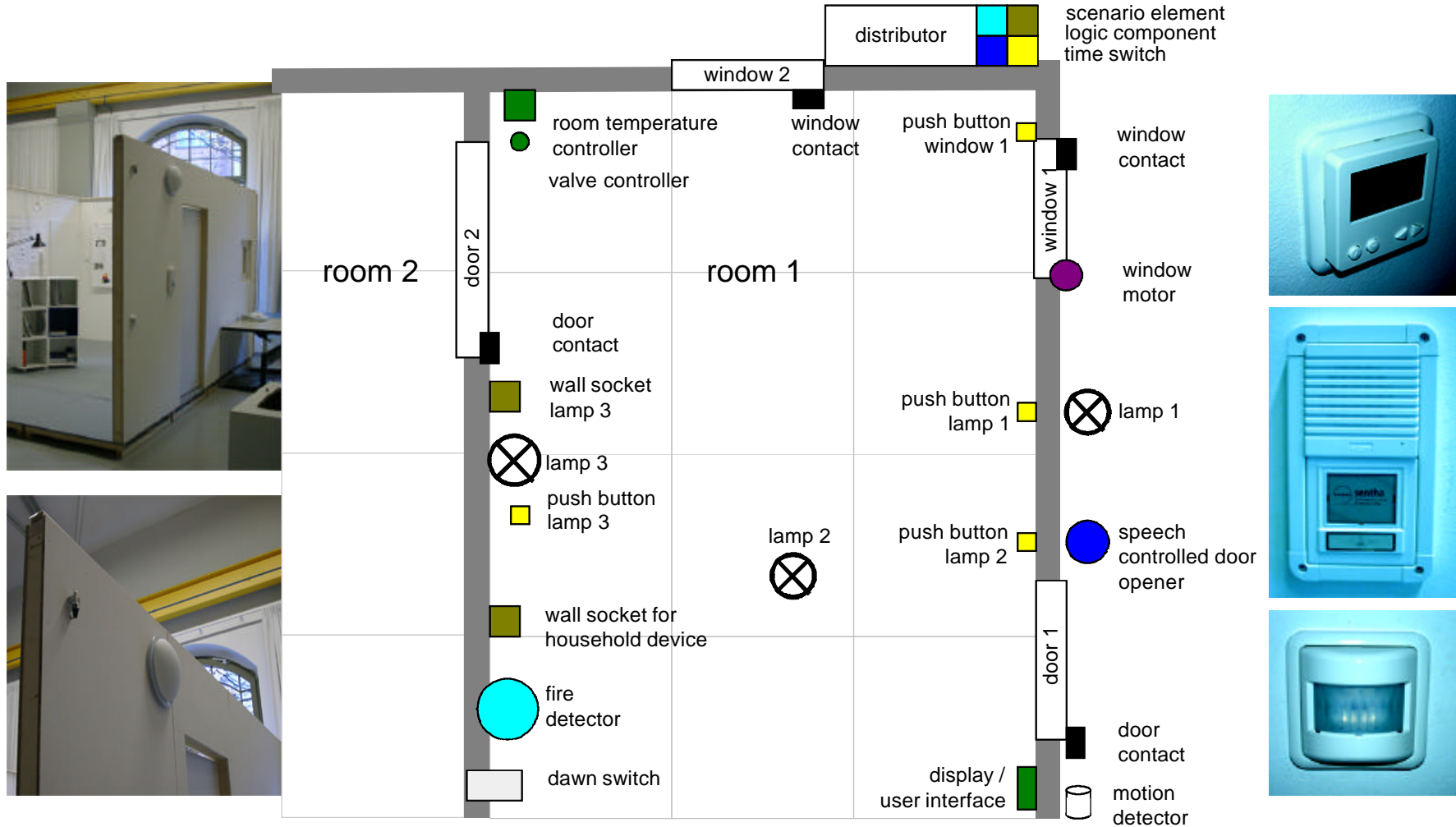

User Interfaces for Smart Homes

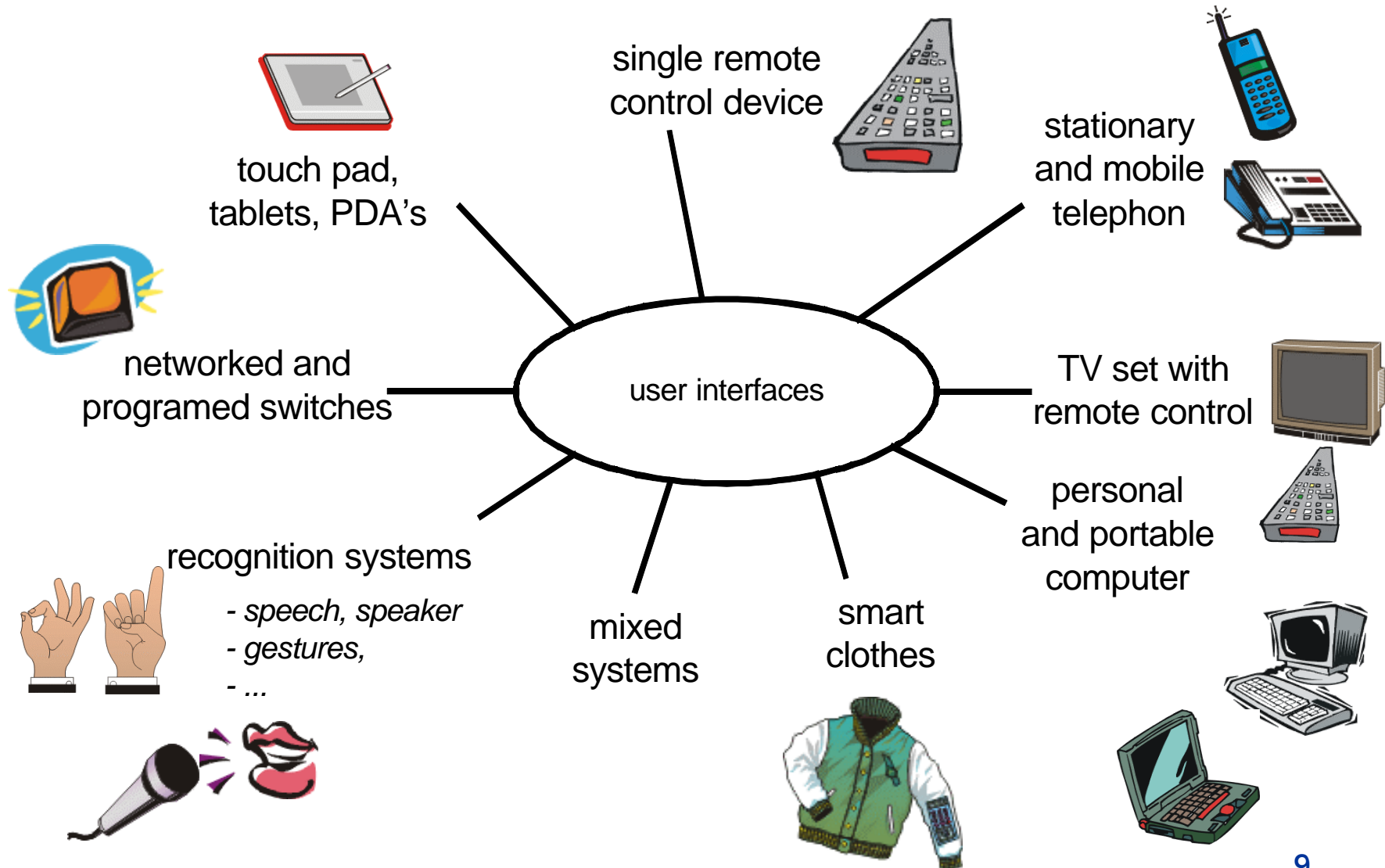

Influence parameters for speech recognition systems

- speech dialog structure,
- user discipline,
- error handling,
- feedback control,
- background noise, non-speech effects,
- system activation,
- speech vocabulary,
- training period,
- hardware design.

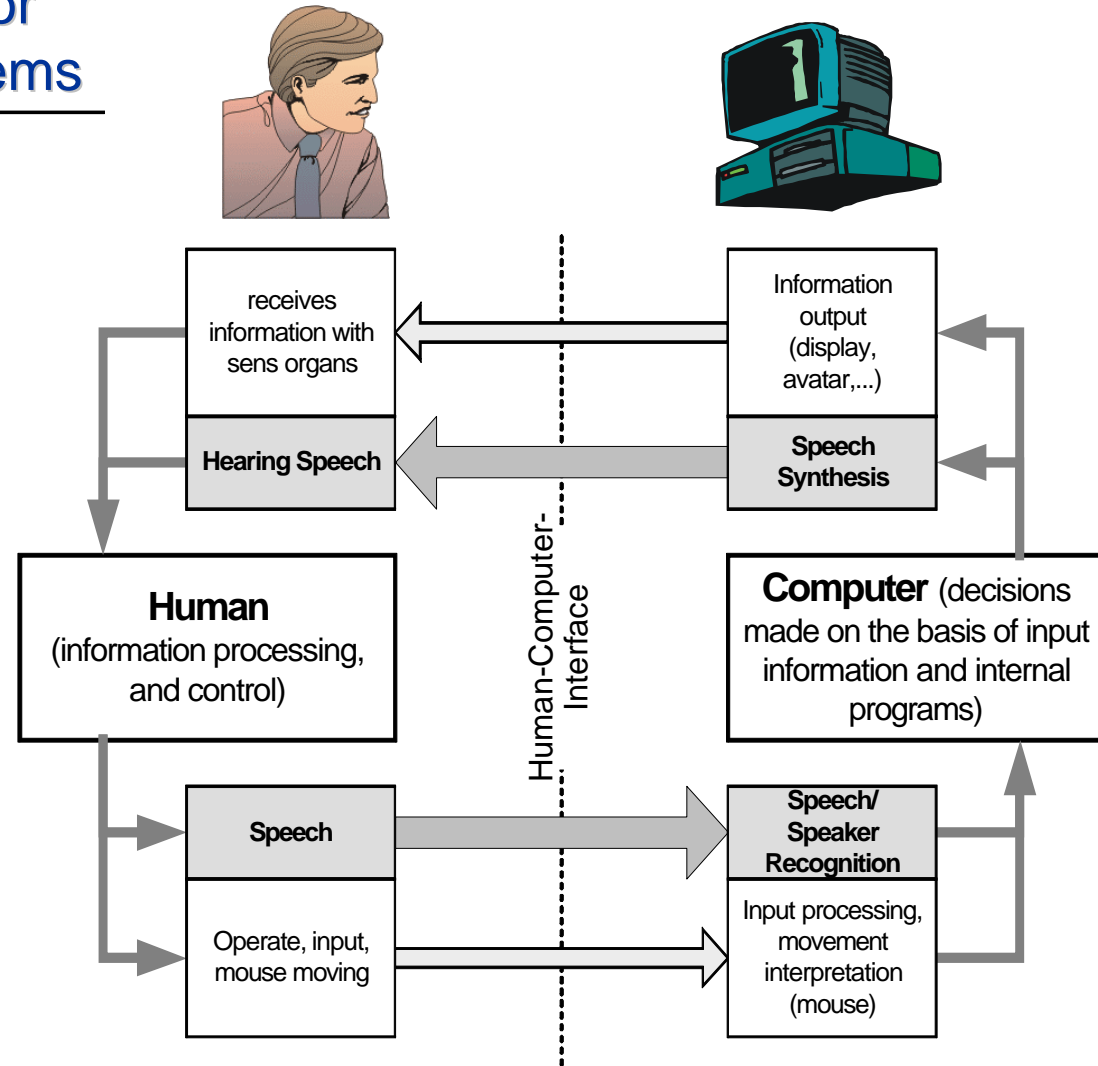

Voice Control of...

- telephone (acoustic dialing)
- tv and hifi devices
- alarm systems
- household appliances
- environment control systems (light, heating, air conditioner,...)
- door/window opener
- robots

Isolated word recognition (speaker adaptive)

- many systems on the market
- very different recognition accuracy (70...95%)
- mostly as add-on to PCs (software solution), very few stand-alone systems
- low price (range \$10...\$100)
- (mostly) serious adaptation/integration problems
- (mostly) awkward training procedures
- noise sensitivity

Continuous speech recognition

- few systems on the market
- very different recognition accuracy (60...80%)
- mostly as add-on to PCs (software solution), very few stand-alone systems
- expensive (> \$100)
- (mostly) serious adaptation / integration problems
- (mostly) awkward training procedures
- noise sensitivity

...need for smart home applications ???

Speaker Recognition

Principle of speaker recognition

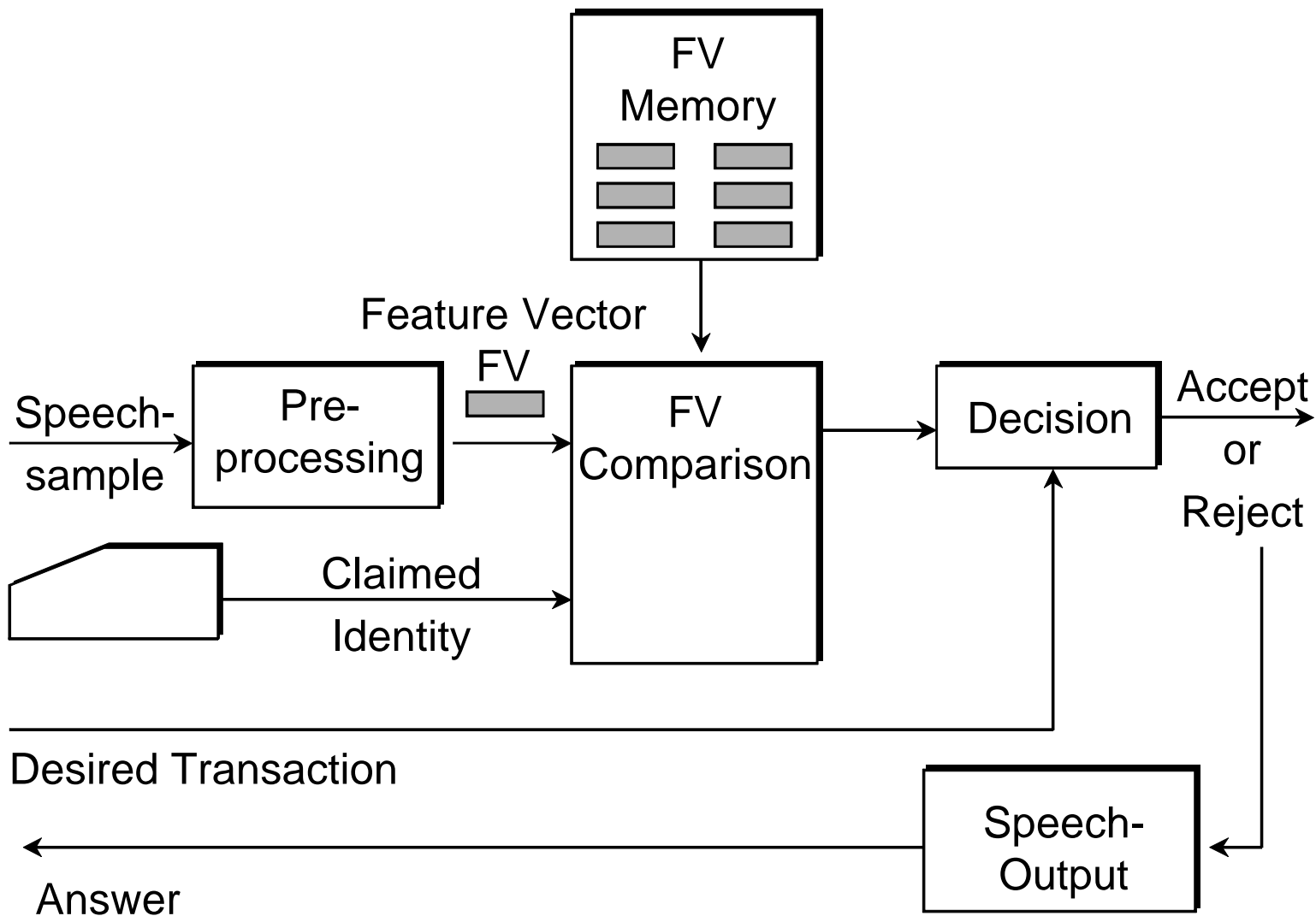

Speech Dialog:

Example: opening of the main door

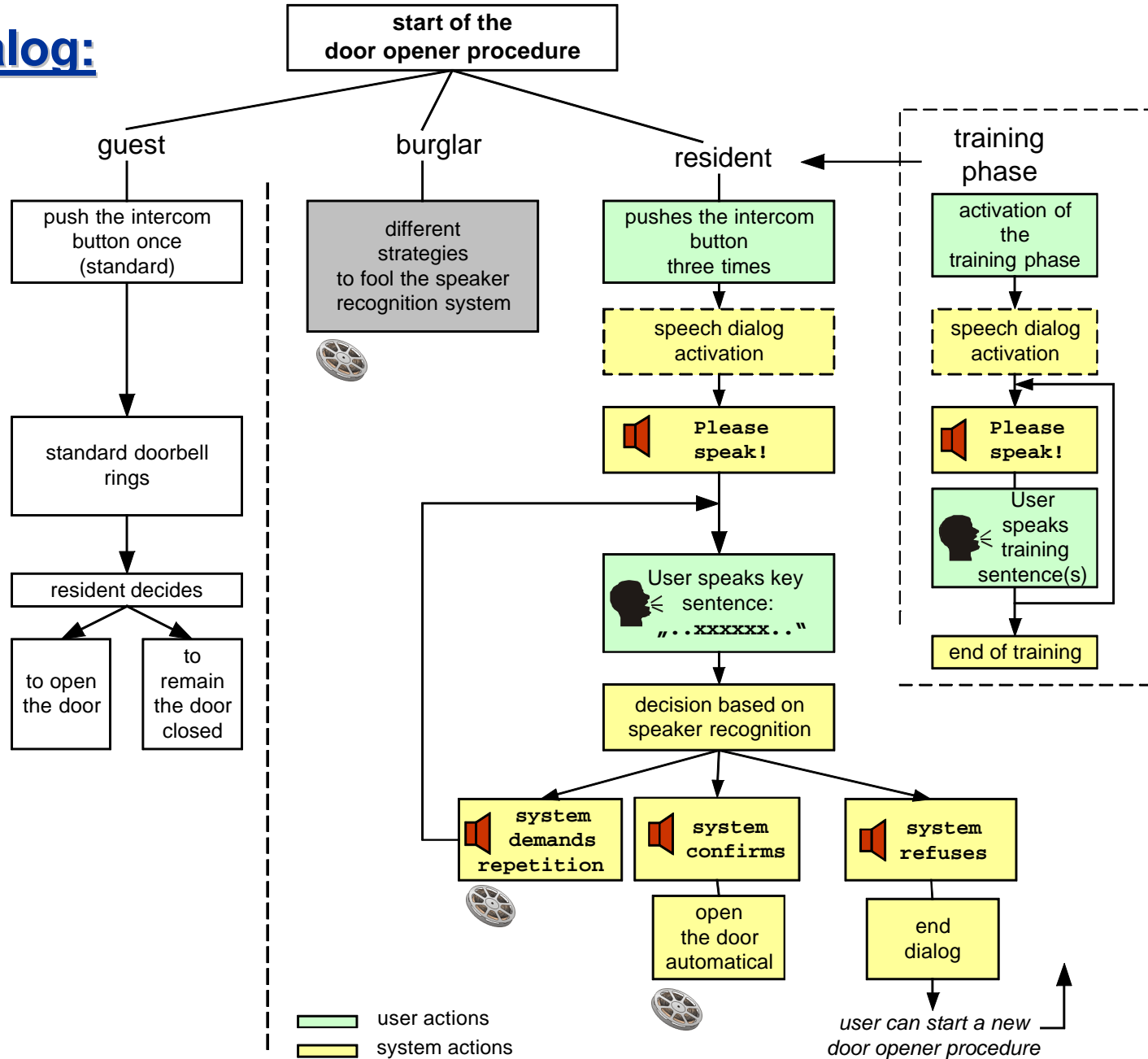

Investigations and Results

Evaluation of young and elderly persons about pro's and cont's of a speech recognition system

Results:

- Speech recognition (voice control) is the top solution, if ...
 - the recognition accuracy is high enough (>95 %)
 - the user has a certain experience
 - it is used for simple command and control functions
- For control of more complex functions a *mixed* interface (graphic, audio,...) is preferable → better for feedback and error handling.



- System training was too long (50 sentences were necessary)
→ decrease of concentration and speaking discipline.
- User became impatient, made comments and turned their face away from the microphone.
- A little insight into the mechanism of speech recognition improved the results.
- An acoustic or visual signal as request to start speaking was found to be very useful.



Summary and Conclusions

- Speech components have been proved as very important in a smart home environment.
- Concerning the successful use of speech and speaker recognition, there was no significant difference between younger and older users, but experience and training played a key role.
- A careful design and integration of the speech interface is of crucial importance.
- Speech components have to be carefully embedded into a general human computer interaction concept. The key problem is the optimal mixture of acoustic and visual information in both, the input and the output interface. The mixture differs individually and must be adapted individually.
- Human computer interaction must not restrict the personal freedom to do things 'by hand', the feeling to be dependend on a technical system has to be avoided.